

Inspection & Measurement System

G70 System



The Sapphire G70 is a remarkable inspection and measurement system for virtually anything that can flow through a pipe.

From soups and sauces to meat products, the G70 offers improved contaminant detection prior to filling in pouches, jars or cans.

With a removeable pipe section, hygiene is at the core of the G70 design. Our industry leading calibration procedure ensures optimum performance without having to purge the inspection pipe.

With advanced linear array technology, the Sapphire G70 detects a wide range of contaminants as well as providing one of the highest accuracies for real time fat/lean analysis in meat to +/-0.2%.

Superior Performance

- Real time fat/lean meat analysis.
- Contaminant detection (metal, stone, glass, bone and certain plastics).
- Automatic changeover between products.
- User programmable durations.
- Designed for washdown environments for easy dismantle and cleaning.



Key Features

- ▶ Third generation inspection and measurement system for pipeline products.
- ▶ Fat/lean analysis on meat to.
- ▶ 20,000 litres p/h or 20 tonnes p/h.
- ▶ Automatic changeover between products.
- ▶ Quick and easy wash down
- ▶ Easy user interface and controls
- ▶ Label print out facility.

Sapphire Inspection Systems

New Cambridge House
Litlington
Royston
Hertfordshire SG8 0SS

t. 01763 853399 e. sales@sapphire-inspection.com



www.sapphire-inspection.com

Specifications

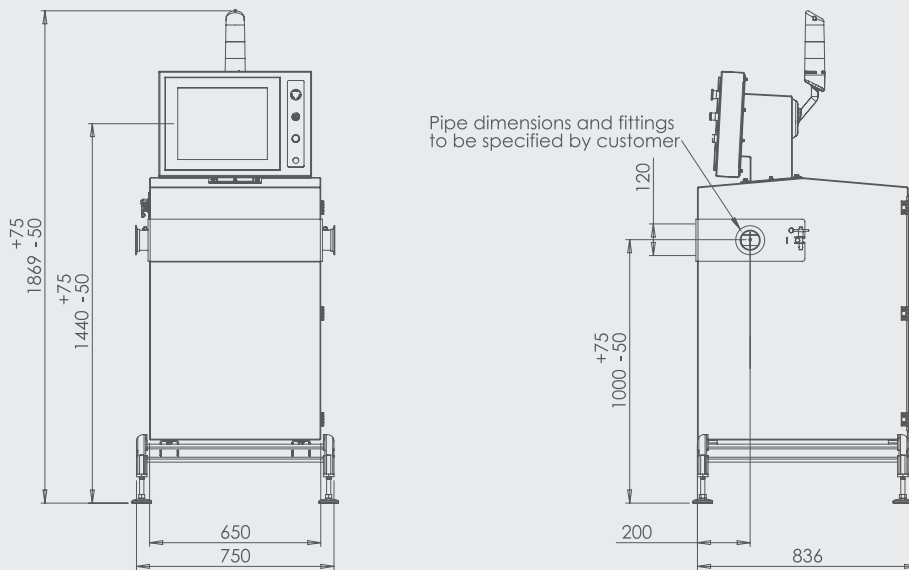

G70 Specifications

Rates	Up to 20,000 litres p/h or 20 tonnes p/h
Detector Array Length	Up to 358 mm
Maximum Line Rate	2000 lines per second
Resolution	256 grey levels per pixel
Video Display	15" colour touchscreen with real-time images and diagnostics
Fat Sampling Interval	User settable. Default is one sample set per 500 scan lines
Fat Graphical Display	User settable. Default is one point per 10 sample sets
Batch Duration	User settable. Default is 10 minutes
Calibration	Self-Calibrating during normal operation
Detection Limit	0.1% fat
Range	2% fat to 70% fat
Linearity	+/- 0.3% from 6% fat to 50% fat
Power Requirements	110 VAC or 200-240 VAC at 1000VA
Dimensions (LxWxH)	650 x 750 x 1730 mm



**Pembroke College
Cambridge**

Corporate Partner of Pembroke College, Cambridge

Sapphire - Always at the forefront

Formed in 2006 from founding research and design parent company Cheyney, Sapphire is renowned as the innovator of low energy inspection.

With stellar designers and Cheyney technology, our Sapphire systems are quick to install, easy to use and unrivalled in the industry for speed, sensitivity and sophistication of detection.



Sapphire Inspection Systems

New Cambridge House
Litlington
Royston
Hertfordshire SG8 0SS

t. 01763 853399 e. sales@sapphire-inspection.com

www.sapphire-inspection.com

