

Innovative Automatic Inspection

G10 System



The Sapphire G10, although our most compact machine, is unrivalled in its class for speed, sensitivity and sophistication of detection.

Designed for the food industry, the G10 is a versatile system offering inspections for packaged products such as confectionary, bakery, frozen and convenience foods as well as loose products such as raisins, nuts and dried fruit.

Superior contaminant identification is achieved using Sapphire's exclusive capabilities for high sensitivity imaging thanks to our expertise in low energy technology. In addition to contaminant check, your G10 will also check fill levels and confirm product integrity.

This system is designed for simple and efficient operation, with easy user functions and a low cost making the Sapphire G10 the ideal entry level inspection system.

Superior Performance

- Contaminant detection (metal, stone, glass, bone and certain plastics).
- Scans for missing and broken parts.
- Detects fill levels.
- Designed for food industry standards.



Key Features

- ▶ Compact but powerful x-ray inspection system.
- ▶ Inspects large product range including bulk flow.
- ▶ Easy set up and operation.
- ▶ Quick and easy wipe down.
- ▶ 24-hour worldwide system support.

Sapphire Inspection Systems

New Cambridge House
Litlington
Royston
Hertfordshire SG8 0SS

t. 01763 853399 e. sales@sapphire-inspection.com



www.sapphire-inspection.com

Specifications

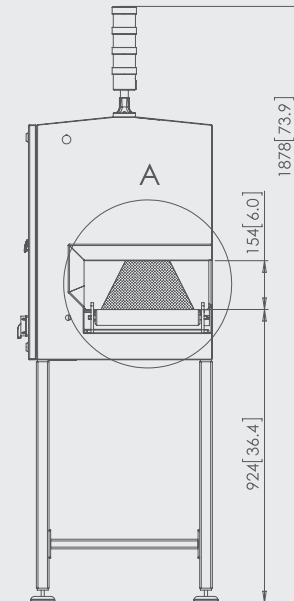
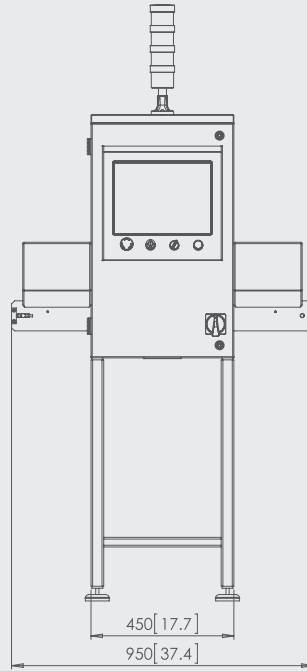
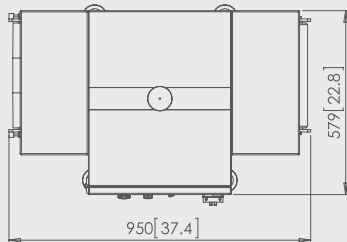

G10 Specifications	
Technology	Computer-controlled 'Low Energy' Technology
X-Ray Generator	60kV computer controlled
Conveyor Speed	0-50 m/min customer specified
Detector Array Length	Up to 307 mm
Maximum Line Rate	2000 lines per second
Resolution	4096 grey levels per pixel
Video Display	15" colour touchscreen with real-time images and diagnostics
Calibration	Self-Calibrating during normal operation
Detection Limit	0.4-1.2 mm stainless steel typical, dependent on product
Inspection Rate	Up to 200 packs/minute
Power Requirements	110 VAC or 200-240 VAC at 500VA
Dimensions (LxWxH)	950 x 580 x 1530 mm



**Pembroke College
Cambridge**

Corporate Partner of Pembroke College, Cambridge

Sapphire - Always at the forefront

Formed in 2006 from founding research and design parent company Cheyney, Sapphire is renowned as the innovator of low energy inspection.

With stellar designers and Cheyney technology, our Sapphire systems are quick to install, easy to use and unrivalled in the industry for speed, sensitivity and sophistication of detection.



Sapphire Inspection Systems

New Cambridge House
Litlington
Royston
Hertfordshire SG8 0SS

t. 01763 853399 e. sales@sapphire-inspection.com



www.sapphire-inspection.com