

# Sophisticated, Entry Level X-Ray System

A Series



The A Series is a compact but sophisticated, entry level x-ray system for automatic, end of line inspection.

Compact enough to fit into an existing production line, the A Series from Sapphire can inspect any product format from trays, pouches and cans to loose product.

Superior contaminant identification is achieved using Sapphire's exclusive capabilities for high sensitivity imaging thanks to our expertise in low energy technology.

Sapphire's A Series combines advanced linear array technology with inspection algorithms proven for the most difficult inspections.

In addition to contaminant inspection, the A Series confirms count, mass, fill levels and detects broken or missing parts.

## Superior Performance

- Contaminant detection (metal, stone, glass, bone and certain plastics).
- Scanning for mass, missing or broken products.
- Detecting packing voids.
- Automatic calibration



## Key Features

- ▶ Most compact Sapphire system
- ▶ Inspects wide range of product formats
- ▶ Hygienic design, up to FSMA standard
- ▶ Quick and easy wash down
- ▶ Easy user interface and controls
- ▶ 24-hour worldwide system support

## Sapphire Inspection Systems

New Cambridge House  
Litlington  
Royston  
Hertfordshire SG8 0SS

t. 01763 853399 e. [sales@sapphire-inspection.com](mailto:sales@sapphire-inspection.com)



[www.sapphire-inspection.com](http://www.sapphire-inspection.com)

## Specifications

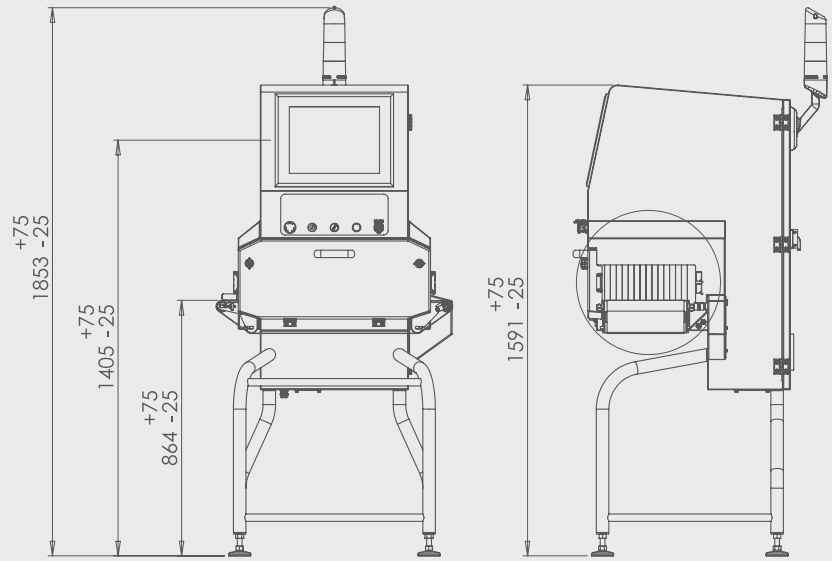
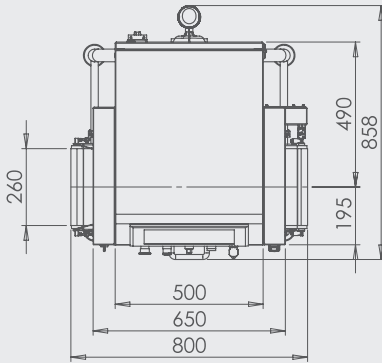

### A Series Specifications

Technology	Computer-controlled 'Low Energy' Technology
X-Ray Generator	70kV glass computer controlled
Conveyor Speed	0-50 m/min customer specified
Detector Array Length	Up to 307 mm
Maximum Line Rate	2000 lines per second
Resolution	4096 grey levels per pixel
Video Display	15" colour touchscreen with real-time images and diagnostics
Calibration	Self-Calibrating during normal operation
Detection Limit	0.4-1.2 mm stainless steel typical, dependent on product
Inspection Rate	Up to 200 packs/minute
Power Requirements	110 VAC or 200-240 VAC at 500VA
Dimensions (LxWxH)	950 x 580 x 1530 mm



**Pembroke College  
Cambridge**

Corporate Partner of Pembroke College, Cambridge

## Sapphire - Always at the forefront

Formed in 2006 from founding research and design parent company Cheyney, Sapphire is renowned as the innovator of low energy inspection.

With stellar designers and Cheyney technology, our Sapphire systems are quick to install, easy to use and unrivalled in the industry for speed, sensitivity and sophistication of detection.



### Sapphire Inspection Systems

New Cambridge House  
Litlington  
Royston  
Hertfordshire SG8 0SS

t. 01763 853399 e. sales@sapphire-inspection.com



www.sapphire-inspection.com